

Cone-Tip Bonded Neoprene Spindle – Inch

- Black neoprene, hardness: 70-80 Shore A
- Temperature Range: -20°C to 100°C [-22°F to 212°F]
- Oil resistant, LABS (silicone) free
- Includes jam nuts

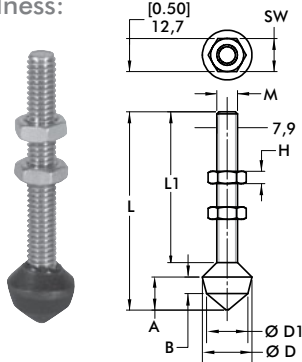

Part No.	M	L	L1	SW	H	A	B	ØD	ØD1
▲ 305208	#10-32	[1.50] 38,1	[1.00] 25,4	[0.38] 9,5	[0.13] 3,3	[0.38] 9,5	[0.19] 4,8	[0.56] 14,2	[0.44] 11,2
▲ 213208	1/4-20	[2.25] 57,2	[1.56] 39,6	[0.44] 11,2	[0.16] 4,0				
▲ 509208	5/16-18	[3.00] 76,2	[2.28] 57,9	[0.50] 12,7	[0.19] 4,8	[0.50] 12,7	[0.25] 6,4	[0.75] 19,1	[0.63] 16
▲ 519208		[5.50] 139,7	[4.75] 120,7						
▲ 210208	3/8-16	[3.50] 88,9	[2.50] 63,5	[0.56] 14,2	[0.23] 5,8	[0.75] 19,1	[0.41] 10,4	[0.88] 22,4	[0.75] 19,1

Large Diameter Padded Swivel Foot Spindle-Inch

- White neoprene, hardness: 70-80 Shore A
- Temperature Range: -40°C to 105°C [-40°F to 220°F]
- Non-marking neoprene
- Includes jam nuts

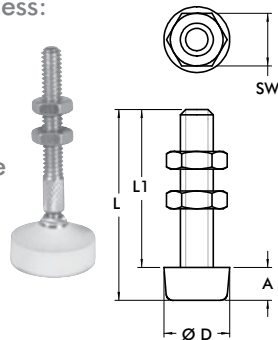

Part No.	M	L	L1	SW	H	A	ØD	Swivel Angle
▲ 207209	1/4-20	[2.56] 65	[1.56] 39,6	[0.44] 11,2	[0.16] 4		[1.00] 25,4	14°
▲ 507209	5/16-18	[2.98] 75,7	[1.94] 49,3	[0.50] 12,7	[0.19] 4,8	[0.31] 8	[1.50] 38,1	24°
▲ 210209	3/8-16	[3.56] 90,4	[2.44] 62	[0.56] 14,2	[0.23] 5,8		[2.00] 50,8	26°

Plunger-matic Assemblies

- For use with Straight Line Action clamps
- Internal compression spring compensates for variations in material thickness
- Zinc plated
- Includes jam nut

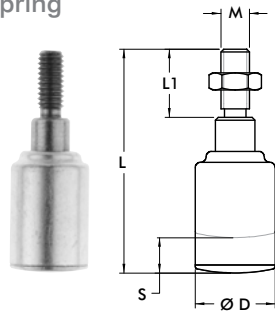

Part No.	M	L	L1	ØD	Max. Compression S	Spring Constant [lbf./in] N/mm	Max. Force [lbf.] N
▲ 905	5/16-18	[2.50] 63,5	[0.75] 19,1	[0.88] 22,2	[0.19] 4,8	[750] 131	[135] 600
● 905-M	M8						
▲ 920	3/8-16	[3.63] 92,2	[1.13] 28,6		[0.38] [9,6]	[822] 144	[308] 1370
● 920-M	M10						

Swivel Foot Spindle

- Includes jam nuts

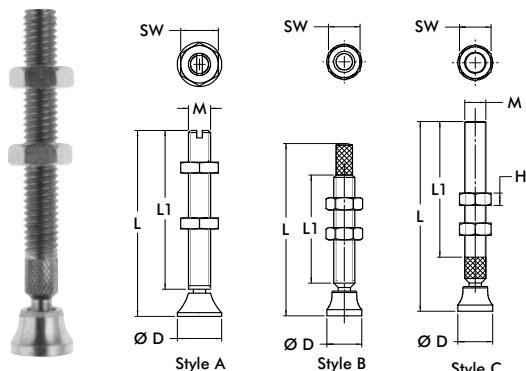

Part No.	M	Style	L	L1	SW	H	ØD	Swivel Angle
■ 207206-M	M6	A	[2.44] 62	[2.13] 54	[0.39] 10	[0.13] 3,2	[0.47] 12	30°
■ 507206-M	M8		[2.87] 73	[2.46] 62,5	[0.51] 13	[0.16] 4	[0.63] 16	
▲ 468206-M	M10	B	[3.00] 76,2	[2.00] 50,8	[0.67] 17	[0.20] 5	[0.79] 20	24°
■ 210206-M		A	[3.31] 84	[2.80] 71			[0.98] 25	
■ 250206-M	M12	A	[4.72] 120	[4.13] 105	[0.75] 19	[0.24] 6	[0.98] 25	30°
▲ 207206	1/4-20	C	[2.38] 60,5	[1.56] 39,6	[0.44] 11,2	[0.16] 4	[0.50] 12,7	14°
▲ 507206	5/16-18		[2.75] 69,9	[1.94] 49,3	[0.50] 12,7	[0.19] 4,8	[0.56] 14,2	
▲ 468206	3/8-16	B	[3.06] 77,7	[1.92] 48,8	[0.56] 14,2	[0.23] 5,8	[0.63] 16	24°
▲ 210206		C	[3.38] 85,9	[2.41] 61,2				
▲ 250206	1/2-13	C	[4.63] 117,6	[3.44] 87,4	[0.75] 19,1	[0.31] 7,9	[1.00] 25,4	24°

Preferred Market: ▲ NA/SA ■ Europe ● Global