

## Operating pressure max. 500 bar/min 100 bar

This hydraulic block cylinder are single acting with spring retraction. Due to their block shape design, hydraulic block cylinders can be used in a wide range of applications, e.g. clamping, punching, pressing, aligning. The factory made mounting holes allow easy and quick mounting of the cylinder in the horizontal or vertical position.

## Technical characteristics

- Suitable for operating pressures starting from 100 bar onwards.
- Lateral hydraulic connection
- Spring retraction
- Convertible to a double action cylinder
- Glide ring seal with high wear resistance
- No stick-slip effect
- An extended piston rod guide gives high stability when transversal-forces occur
- Piston rod with internal thread

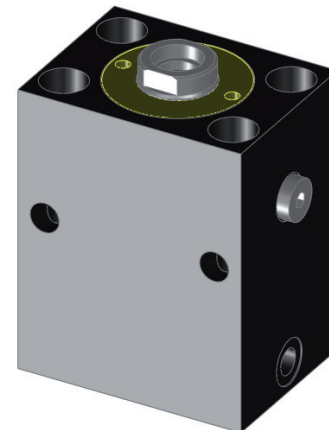

## CUSTOMER DESIGNED MODELS

If you need a special cylinder for your application – customer designed models are available. PLEASE LET US KNOW!

## Important Note

The maximum spring retraction force has been taken into account in the clamping force values. The operating pressure should not exceed 150 bar if the piston is actuated without a counter force.

## Recommended accessories (separate order)

1 straight screw connectors D8S-R1/4

model no.	Clamping force		Repair kit	Piston Ø [mm]	Stroke* S max. [mm]	Piston surface area [cm <sup>2</sup> ]	Oil con- sumption/ stroke [cm <sup>3</sup> ]	Spring retracting force min [N]	Connection G	Weight ~ [kg]
	at 100 bar	at 500 bar								
	[kN]	[kN]								
722E16202-1	1,9	9,7	720V16-0003	16	20	2,01	4,02	50	G1/4	1,0
722E25202-1	4,6	22,9	720V25-0005	25	20	4,91	9,82	104	G1/4	2,0
722E32202-1	7,7	38,4	720V32-0005	32	20	8,04	16,08	200	G1/4	3,0
722E40202-1	12	59,8	720V40-0005	40	20	12,56	25,12	270	G1/4	3,7
722E50202-1	18,9	94,5	720V50-0004	50	20	19,64	39,27	460	G1/4	5,7

Application example

Support is necessary in case of operating pressure over 160 bar

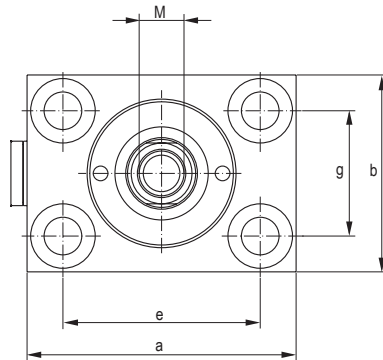
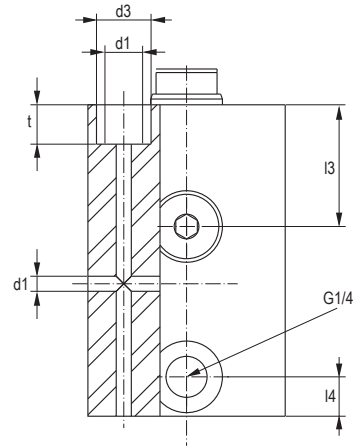
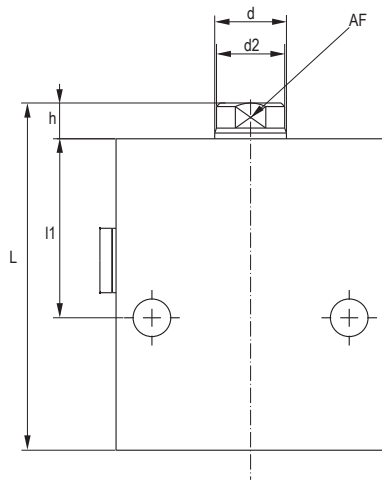
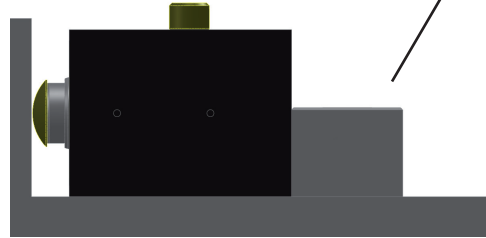

model no.	a	b	c	d	d1	d2	d3	e	g	h	L	l1	l3	l4	M	AF	t	f1
	[mm]														x depth			
722E16202-1	60	35	17,5	10	6,5	9	11	40	22	6	111	44	30,5	11	M 6x15	8	6,8	4,5
722E25202-1	65	45	22,5	16	8,5	15	13,5	50	30	7	114	46	32	11	M10x15	13	9	5,5
722E32202-1	75	55	27,5	20	10,5	19	18	55	35	10	122	50	34	11	M12x18	17	11	7
722E40202-1	85	63	31,5	25	10,5	24	18	63	40	10	123	49	33	11	M16x25	21	11	7
722E50202-1	100	75	37,5	32	13	31	20	76	45	10	135	54	38	13	M20x30	27	13	8