



## Operating pressure max. 500 bar/min 100 bar

Hydraulic double acting block cylinders are particularly suited for applications requiring frequent cycles and rapid stroke speeds. The block design allows a wide range of applications such as clamping, pressing, aligning and punching. The mounting boreholes are a further advantage which allow quick and easy mounting in the horizontal or vertical position.

### Technical characteristics

- Lateral hydraulic connections
- Glide ring seal with high wear resistance
- No stick-slip effect
- Double piston rod seal
- An extended piston rod guide assures high stability when transversal forces occur on the piston.
- Piston rod with internal thread

### CUSTOMER DESIGNED MODELS

If you need a special cylinder for your application – customer designed models are available. PLEASE LET US KNOW!

### Recommended accessories (separate order)

2 straight screw connectors D8S-R1/4

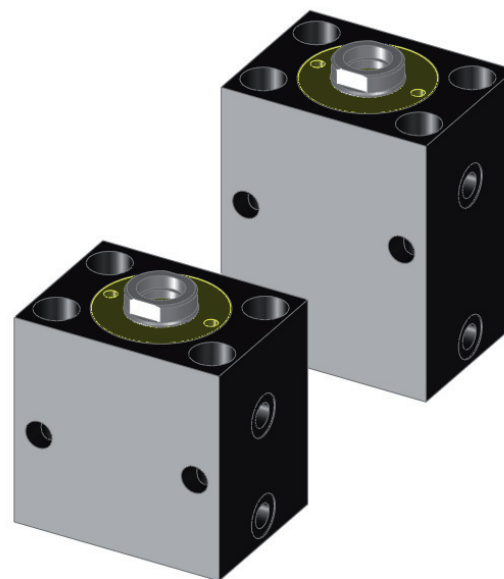

model no.	Clamping force		Repair kit	Piston Stroke*		Piston surface area		Oil consumption		Connection	Weight
	at 100 bar			Ø	S	forward	back	forward	back	G	~
	forward stroke	back stroke		max.	stroke	stroke	stroke	stroke	stroke	2x	[kg]
	[kN]	[kN]	[mm]	[mm]	[cm <sup>2</sup> ]	[cm <sup>2</sup> ]	[cm <sup>3</sup> ]	[cm <sup>3</sup> ]			
722D16162-1	2,0	1,2	720V16-0002	16	16	2,01	1,23	3,20	1,95	G1/4	0,9
722D16502-1	2,0	1,2	720V16-0002	16	50	2,01	1,23	10,05	6,15	G1/4	1,3
722D25202-1	4,8	2,8	720V25-0002	25	20	4,91	2,90	9,82	5,80	G1/4	1,4
722D32252-1	7,9	4,8	720V32-0002	32	25	8,04	4,90	20,10	12,25	G1/4	2,0
722D32502-1	7,9	4,8	720V32-0002	32	50	8,04	4,90	40,20	24,50	G1/4	3,2
722D40252-1	12,3	7,5	720V40-0002	40	25	12,56	7,66	31,40	19,15	G1/4	2,8
722D40992-1	12,3	7,5	720V40-0002	40	100	12,56	7,66	125,70	75,60	G1/4	5,5
722D50252-1	19,3	11,4	720V50-0001	50	25	19,64	11,59	49,10	29,00	G1/4	5,7
722D50502-1	19,3	11,4	720V50-0001	50	50	19,64	11,59	98,20	58,00	G1/4	7,0
722D50992-1	19,3	11,4	720V50-0001	50	100	19,64	11,59	196,40	116,00	G1/4	13,0
722D63252-1	30,0	18,0	720V63-0002	63	25	31,2	18,6	77,9	46,5	G1/4	8,0
722D63502-1	30,0	18,0	720V63-0002	63	50	31,2	18,6	155,9	93,0	G1/4	9,4
722D63802-1	30,0	18,0	720V63-0002	63	80	31,2	18,6	249,4	148,9	G1/4	14,0

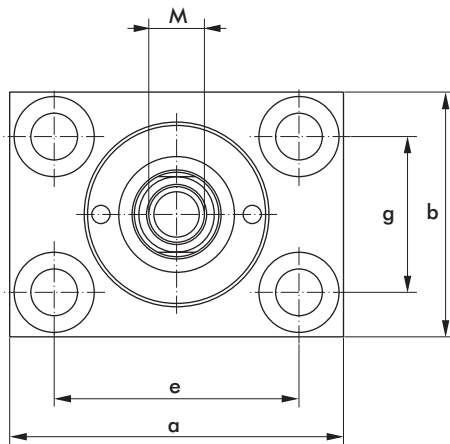
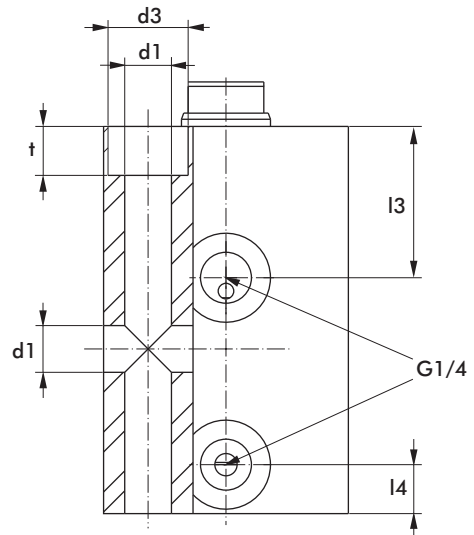
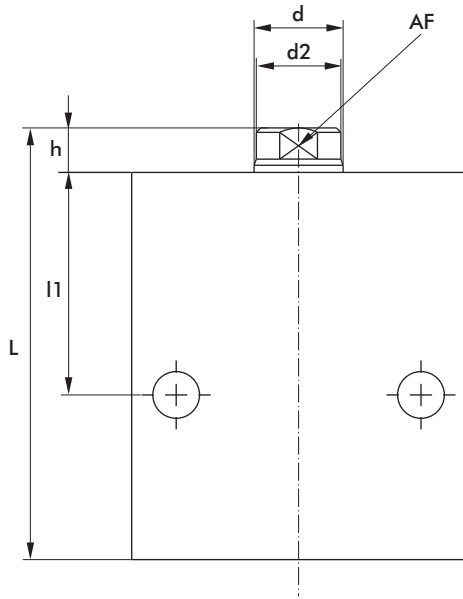

model no.	a	b	c	d	d1	d2	d3	e	g	h	L	l1	l3	l4	M	AF	t	t1
	[mm]																	
722D16162-1	60	35	17,5	10	6,5	9	11	40	22	6	76	44	30,5	11	M 6x15	8	6,8	4,5
722D16502-1	60	35	17,5	10	6,5	9	11	40	22	6	111	44	30,5	11	M 6x15	8	6,8	4,5
722D25202-1	65	45	22,5	16	8,5	15	13,5	50	30	7	84	46	32	11	M10x15	13	9	4,5
722D32252-1	75	55	27,5	20	10,5	19	18	55	35	10	97	50	34	11	M12x18	17	11	7
722D32502-1	75	55	27,5	20	10,5	19	18	55	35	10	122	50	34	11	M12x18	17	11	7
722D40252-1	85	63	31,5	25	10,5	24	18	63	40	10	98	49	33	11	M16x25	21	11	7
722D40992-1	85	63	31,5	25	10,5	24	18	63	40	10	173	49	33	11	M16x25	21	20	7
722D50252-1	100	75	37,5	32	13	31	20	76	45	10	110	54	38	13	M20x30	27	13	8
722D50502-1	100	75	37,5	32	13	31	20	76	45	10	135	54	38	13	M20x30	27	13	8
722D50992-1	100	75	37,5	32	13	31	20	76	45	10	165	56	38	13	M20x30	27	30	8
722D63252-1	125	95	47,5	40	17,5	39	26	95	65	10	110	56	38	13	M24x30	36	16	8
722D63502-1	125	95	47,5	40	17,5	39	26	95	65	10	135	56	38	13	M24x30	36	16	8
722D63802-1	125	95	47,5	40	17,5	39	26	95	65	10	165	56	38	13	M24x30	36	16	8