

GR and RC Series Medium Duty Pivot Units

GR and RC Series Pneumatic Pivot Units

are used in welding applications or anywhere it is necessary to accurately position tooling. Both the RC and GR series can be mounted in an upright vertical or horizontal position.

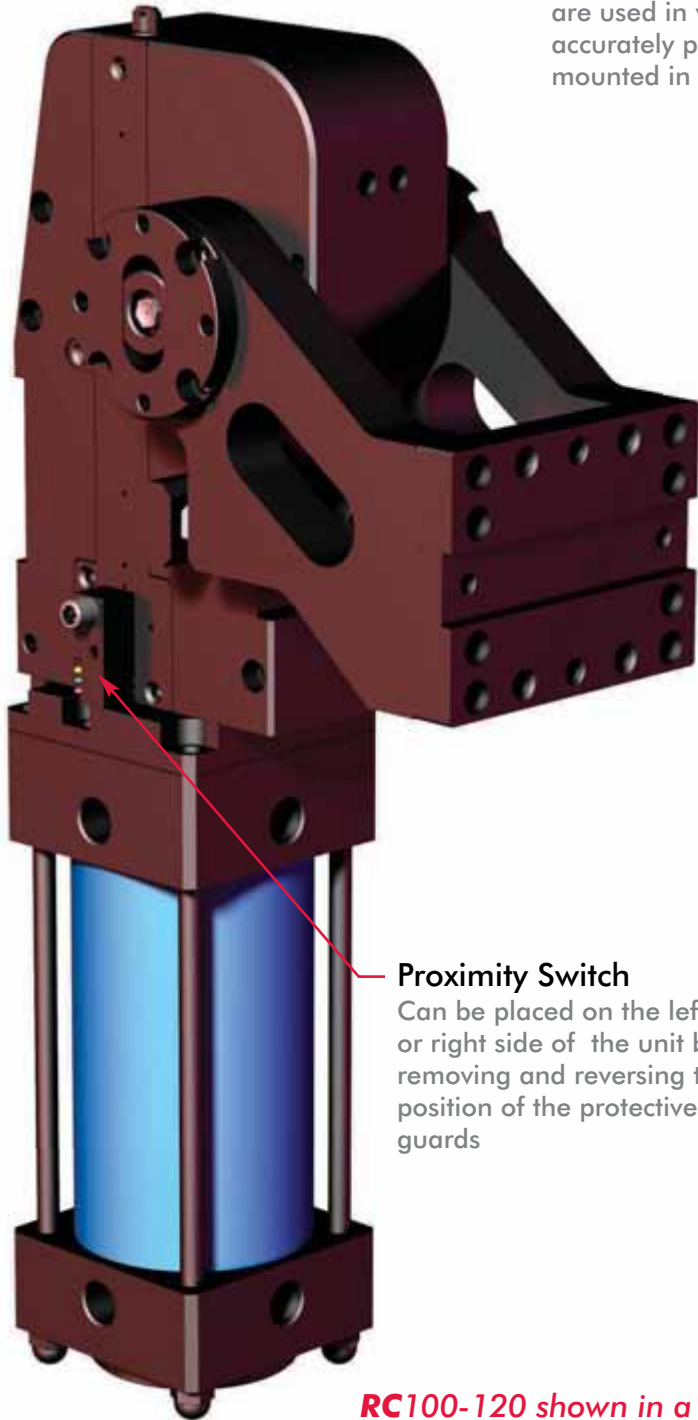

Proximity Switch
Can be placed on the left or right side of the unit by removing and reversing the position of the protective guards

RC100-120 shown in a vertical "V" orientation

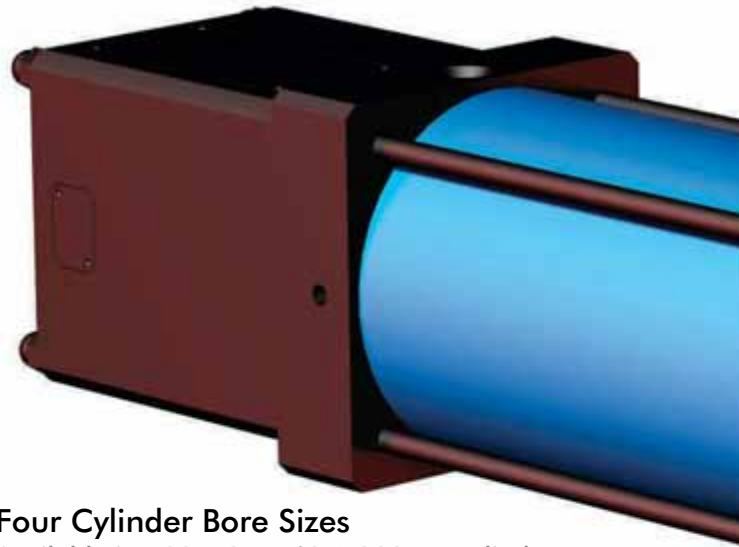

Four Cylinder Bore Sizes

Available in 100, 125, 160 & 200mm cylinder bore sizes. Cylinders are offered with NPT or ISO G ports



Cut Off Valve (GR Series Only)

Stops movement when air pressure is lost.



GR and RC Series Medium Duty Pivot Units

Available in three different arm opening angles

45°, 90° and 120° arm opening angles are available in both the horizontal and vertical mount orientation. Both mounting orientations can also be ordered with an inverted mounting bracket.

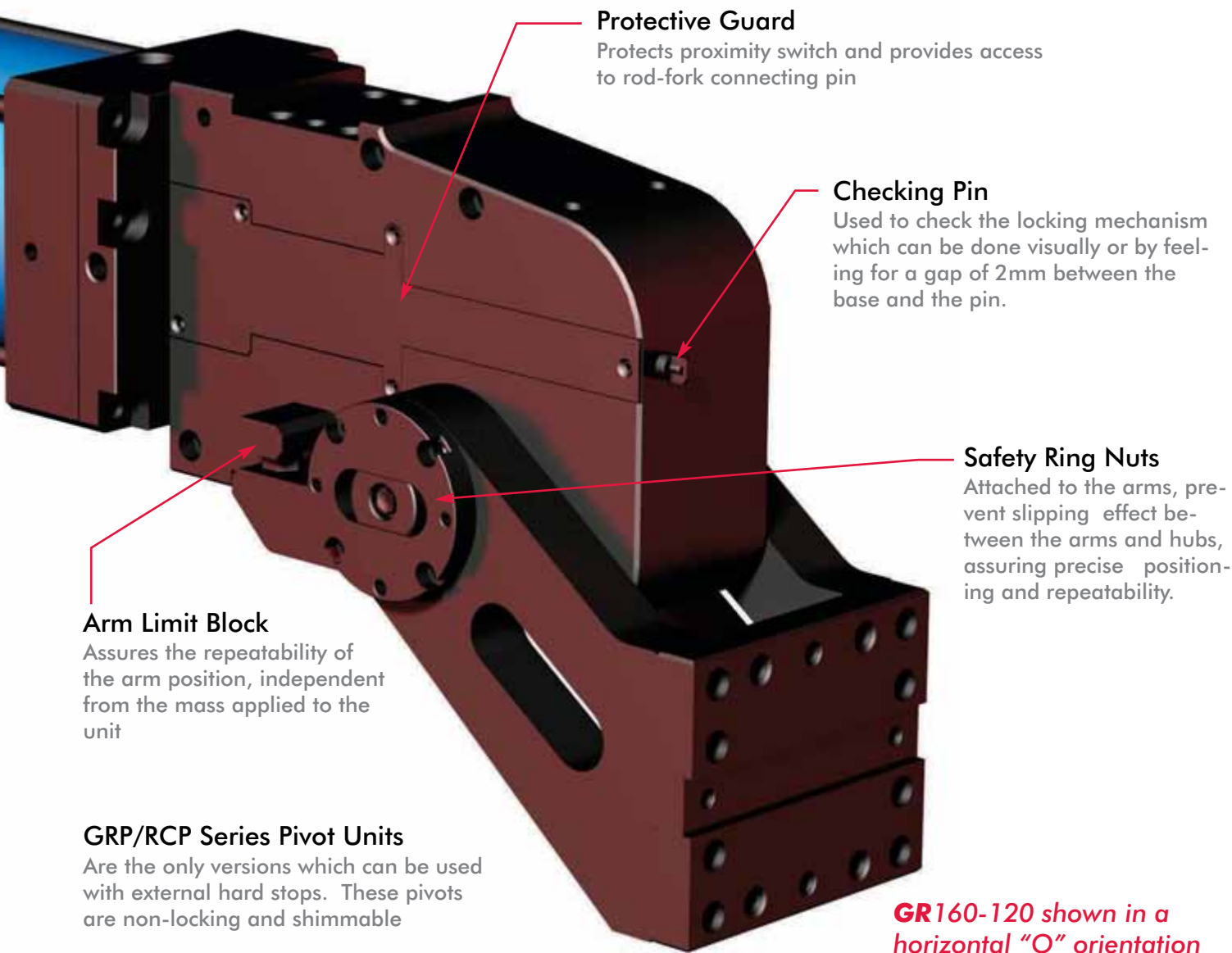

Protective Guard
Protects proximity switch and provides access to rod-fork connecting pin

Checking Pin
Used to check the locking mechanism which can be done visually or by feeling for a gap of 2mm between the base and the pin.

Safety Ring Nuts
Attached to the arms, prevent slipping effect between the arms and hubs, assuring precise positioning and repeatability.

Arm Limit Block
Assures the repeatability of the arm position, independent from the mass applied to the unit

GRP/RCP Series Pivot Units
Are the only versions which can be used with external hard stops. These pivots are non-locking and shimmable

GR160-120 shown in a horizontal "O" orientation

GR and RC Series Medium Duty Pivot Units

Ordering Information

GR

160

120

V

PNEUMATIC PIVOT MODEL

GR = GR SERIES PIVOT UNITS
(HYDRAULIC MOTION CONTROL
WITH BRAKING FEATURE)

***GRP** = GR SERIES PIVOT UNITS
NON LOCKING VERSION
(HYDRAULIC MOTION CONTROL
WITH BRAKING FEATURE)

RC = RC SERIES PIVOT UNITS
(HYDRAULIC MOTION CONTROL
WITHOUT BRAKING FEATURE)

***RCP** = RC SERIES PIVOT UNITS
NON LOCKING VERSION
(HYDRAULIC MOTION CONTROL
WITHOUT BRAKING FEATURE)

CYLINDER OPTIONS

100 = 100MM BORE CYLINDER

125 = 125MM BORE CYLINDER

160 = 160MM BORE CYLINDER

200 = 200MM BORE CYLINDER

OPENING ANGLE

45 = 45°

90 = 90°

120 = 120°

ORIENTATION

O = HORIZONTAL

V = VERTICAL

O/LS = INVERTED HORIZONTAL

V/LS = INVERTED VERTICAL

***ONLY RCP AND GRP PIVOT UNITS
CAN BE USED WITH EXTERNAL HARD
STOPS AND SHIMMING**



GR and RC Series Medium Duty Pivot Units

Ordering Information

PX

0

N

X

CYLINDER POSITION
(SEE BELOW)

- X** = CYLINDER POSITION X
- Y** = CYLINDER POSITION Y
- W** = CYLINDER POSITION W
- Z** = CYLINDER POSITION Z

PORT TYPE
N = NPT PORTS
G = G PORT

PROXIMITY SWITCH TYPE
0 = NO PROXIMITY SWITCH
T = TURCK PROXIMITY SWITCH
P = PEPPERL+FUCHS PROXIMITY SWITCH
PM = PEPPERL+FUCHS PROXIMITY SWITCH (WHITE LED)

PROXIMITY SWITCH LOCATION (SEE BELOW)
P0 = NO PROXIMITY SWITCH
PX = PROXIMITY SWITCH ON THE X SIDE
PY = PROXIMITY SWITCH ON THE Y SIDE

GR & RC Series Optional Cylinder Position (See page 9 for port sizes and locations)

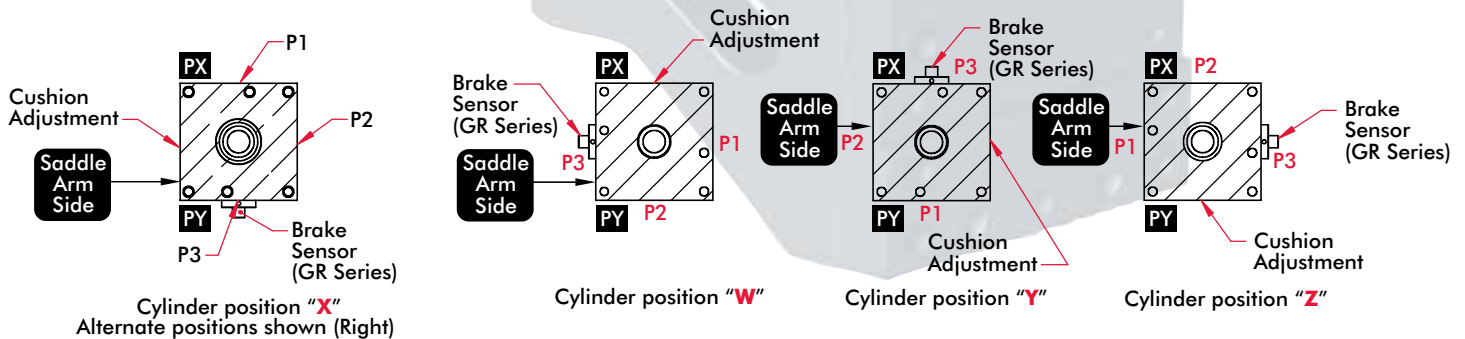

GR and RC Series Medium Duty Pivot Units

GR-RC 100 Vertical Orientation Pivot Dimensions

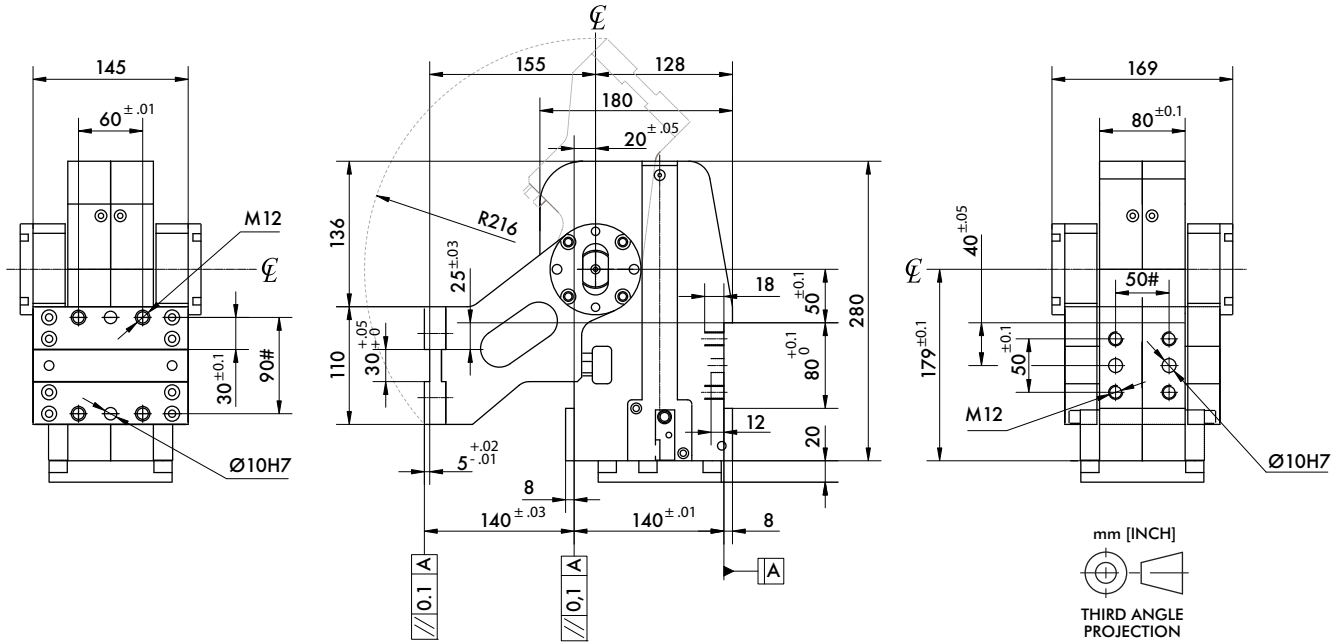

GR-RC 100 Horizontal Orientation Pivot Dimensions

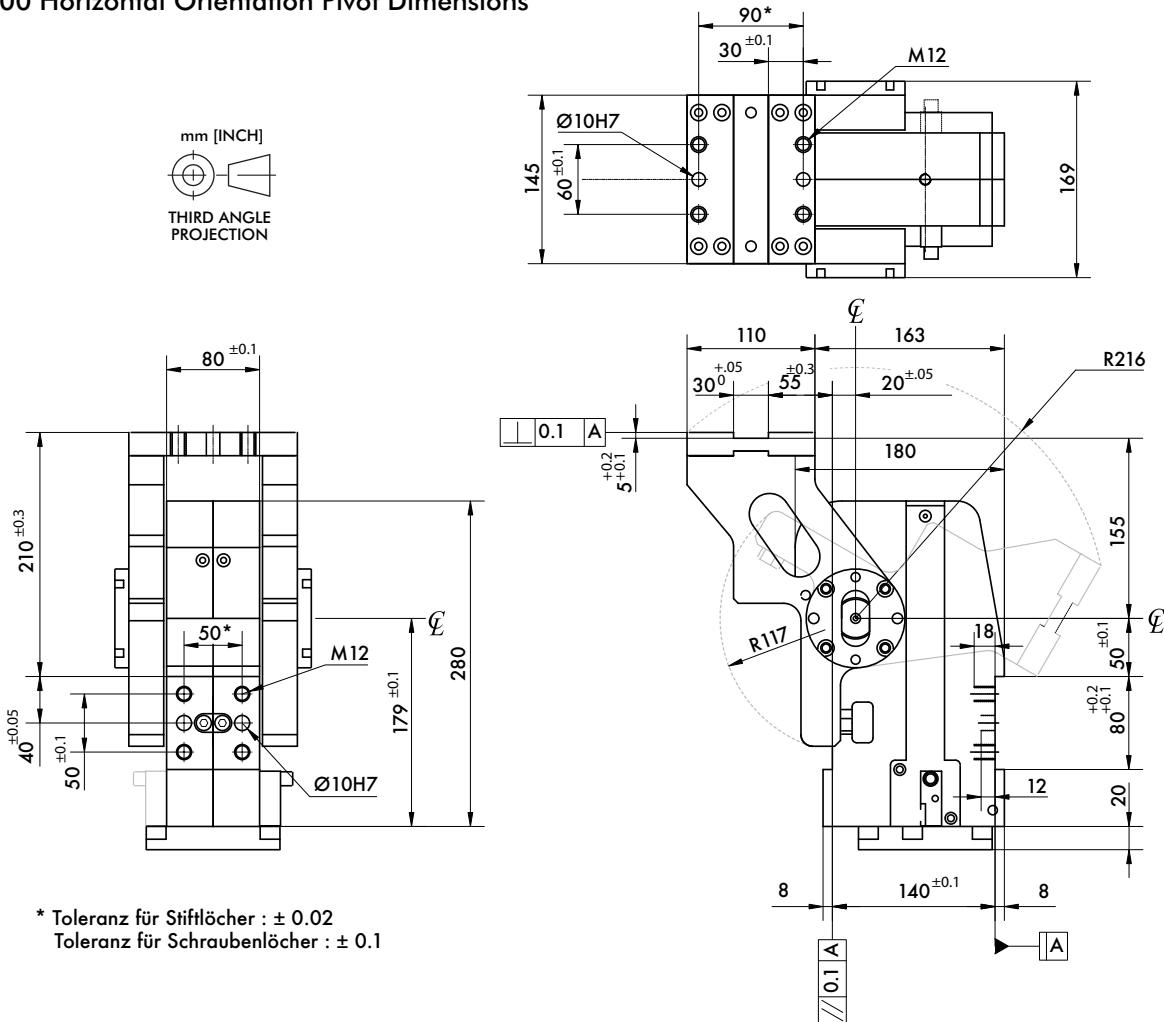

GR-RC 125-160-200 Vertical Orientation Pivot Dimensions

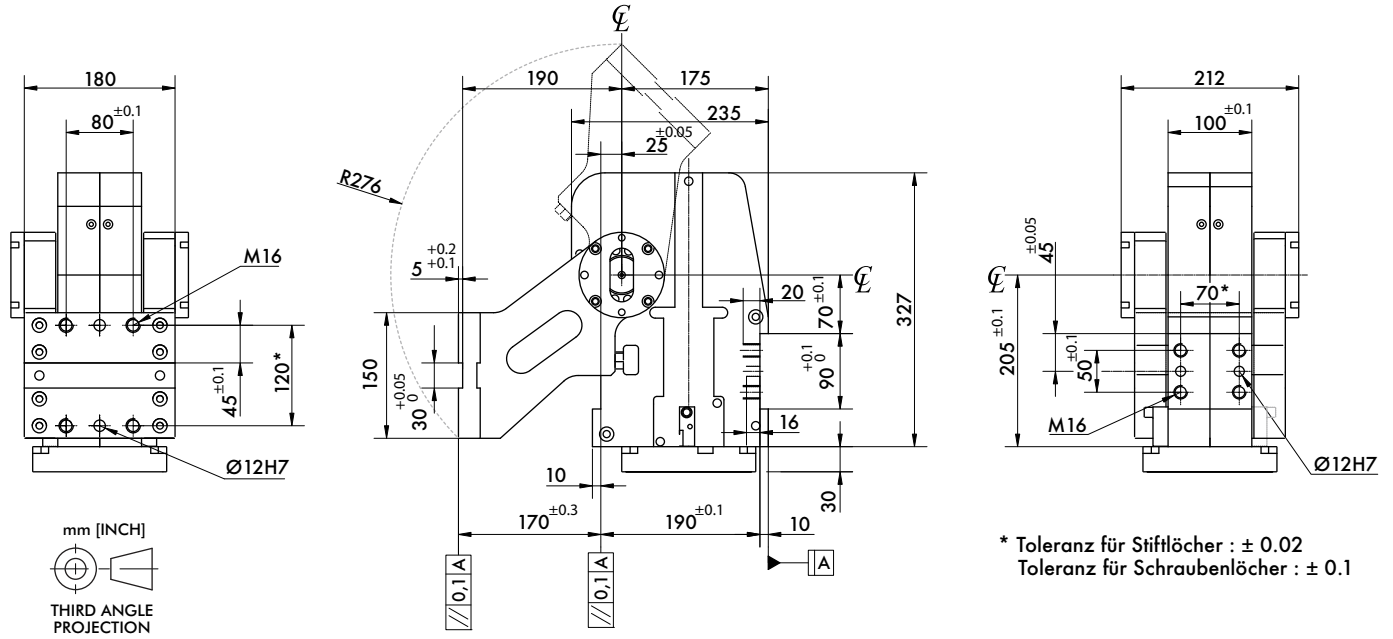

GR-RC 125-160-200 Horizontal Orientation Pivot Dimensions

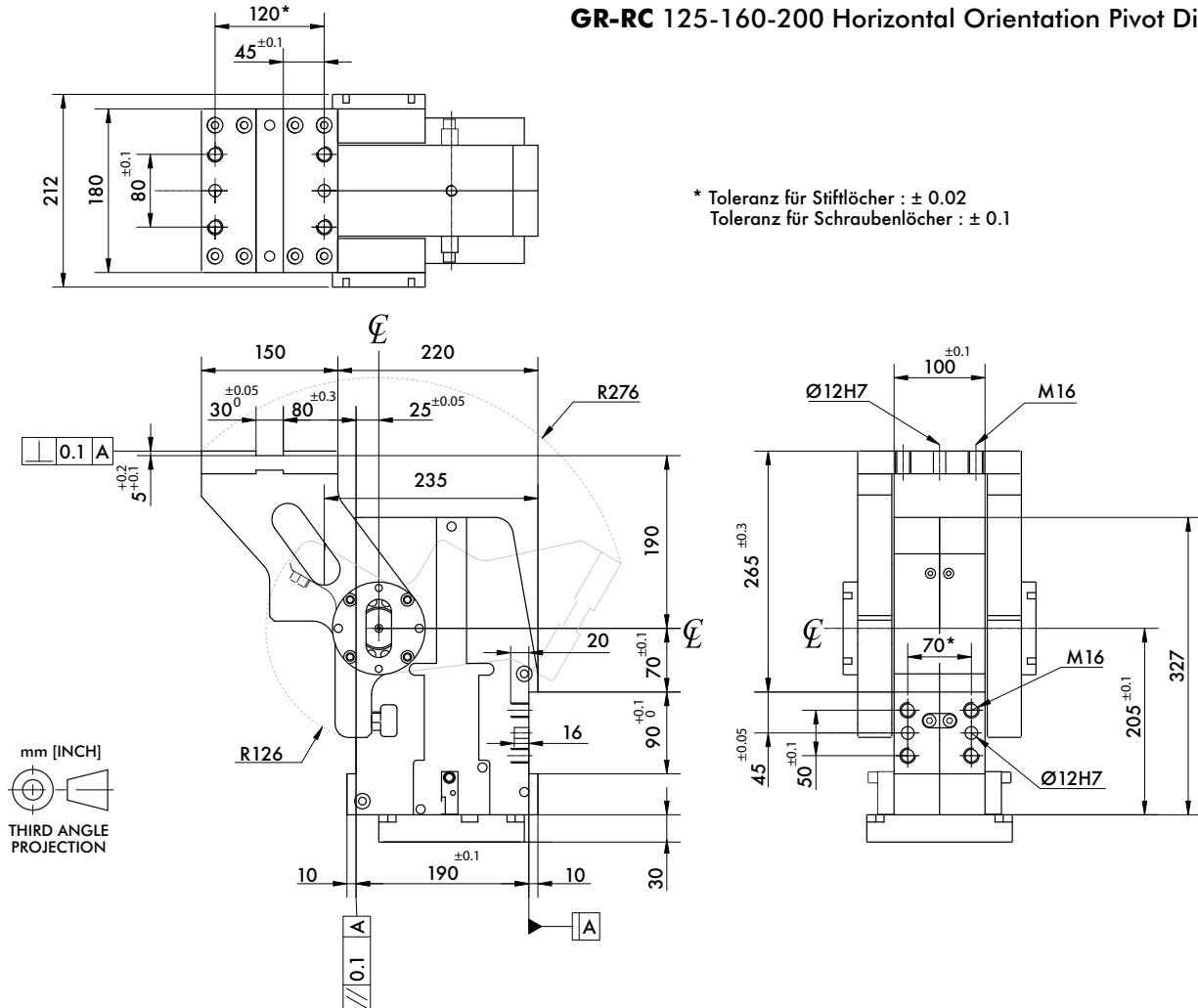

GR and RC Series Medium Duty Pivot Units-Movement

Arm Opening Angle and Saddle Movement

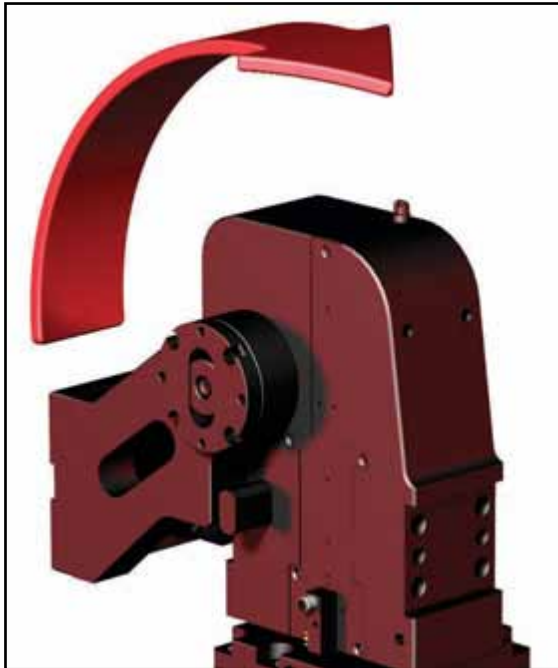

Vertical Saddle Orientation

Arm opening angles offered:
 45° Arm Opening Angle
 90° Arm Opening Angle
 120° Arm Opening Angle

Swivel Arm Position

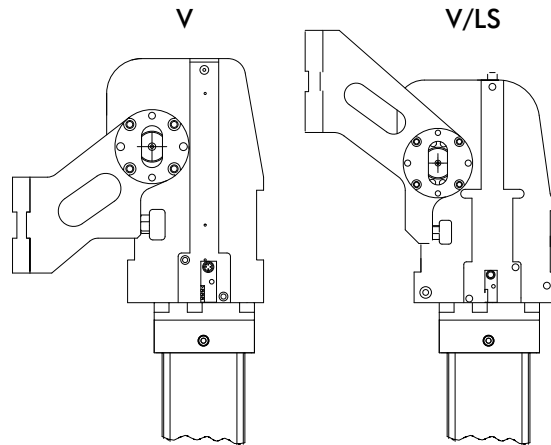

Horizontal Saddle Orientation

Arm opening angles offered:
 45° Arm Opening Angle
 90° Arm Opening Angle
 120° Arm Opening Angle

Swivel Arm Position

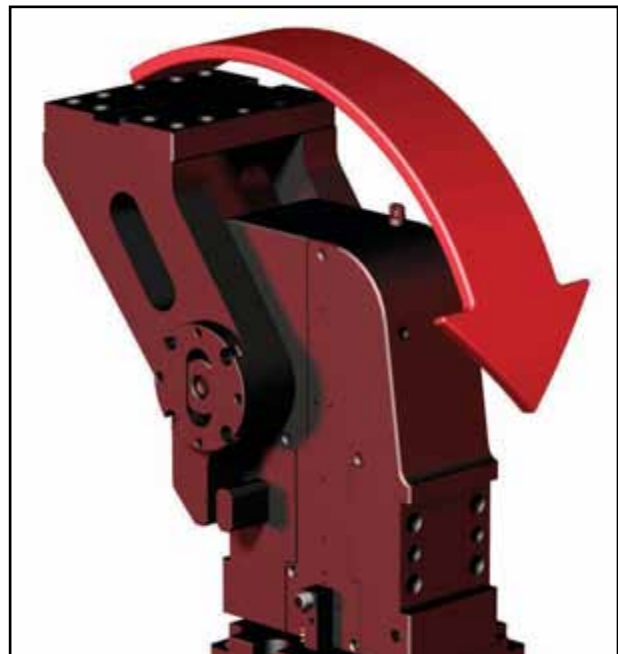
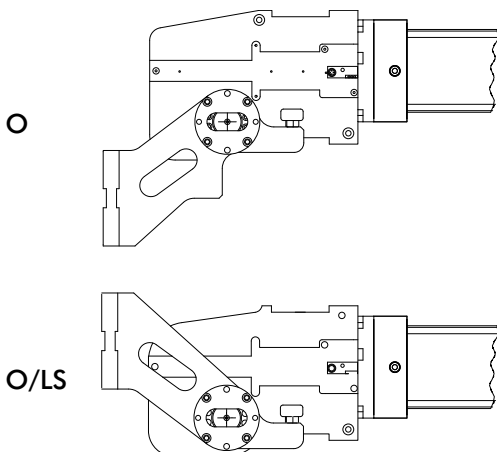

GR and RC Series Medium Duty Pivot Units-Dimensions

Type "LS" Vertical Orientation Dimensions

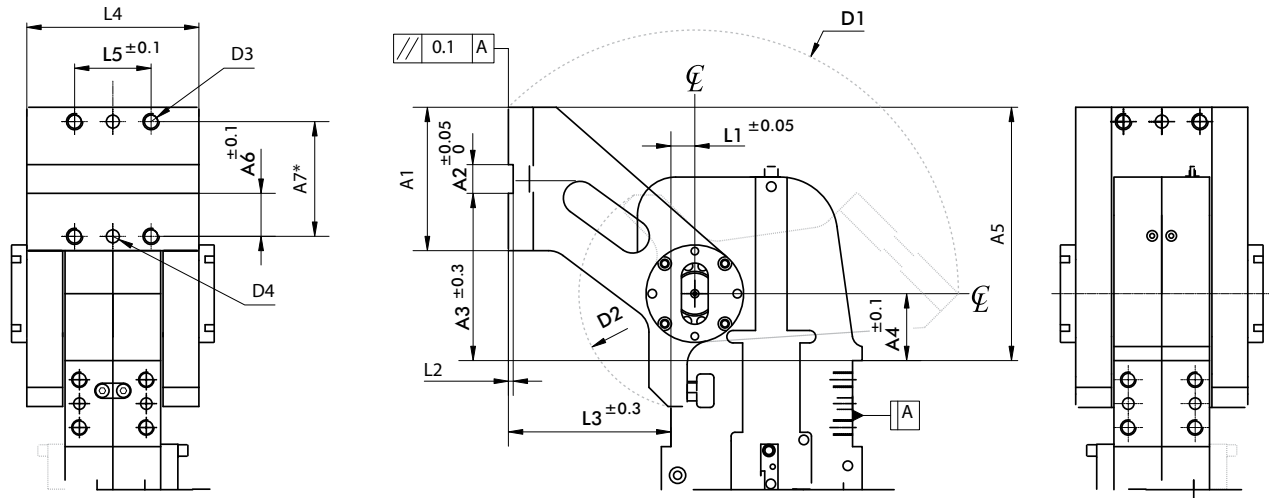

MODEL	A1	A2	A3	A4	A5	A6	A7	L1	L2	L3	L4	L5	D1	D2	D3	D4	H7	Max. opening angle	
	mm												~	~					
GR/RC100-...V/LS	110	30	125	50	195	30	90	20	5	140	145	60	216	117	M12	Ø10		120°	
GR/RC125-...V/LS																			
GR/RC160-...V/LS	150	30	175	70	265	45	120	25	5	170	180	80	276	126	M16	Ø12			
GR/RC200-...V/LS																			

Type "LS" Horizontal Orientation Dimensions

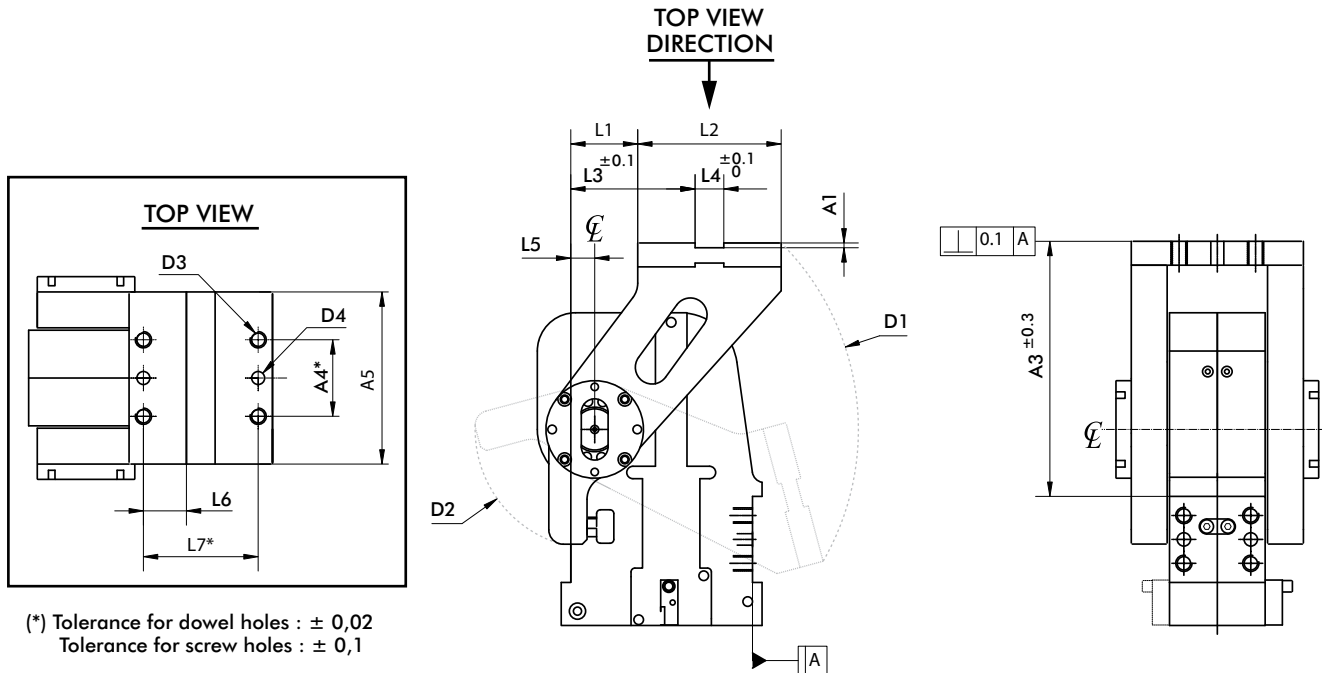

MODEL	A1	A2	A3	A4	A5	L1	L2	L3	L4	L5	L6	L7	D1	D2	D3	D4	H7	Max. opening angle	
	mm												~	~					
GR/RC100-...O/LS	5	50	210	60	145	55	110	95	30	20	30	90	216	117	M12	Ø10		90°	
GR/RC125-...O/LS																			
GR/RC160-...O/LS	5	70	265	80	180	70	150	130	30	25	45	120	276	126	M16	Ø12		80°	
GR/RC200-...O/LS																			

GR and RC Series Medium Duty Pivot Units

GR Series Cylinder Dimensions

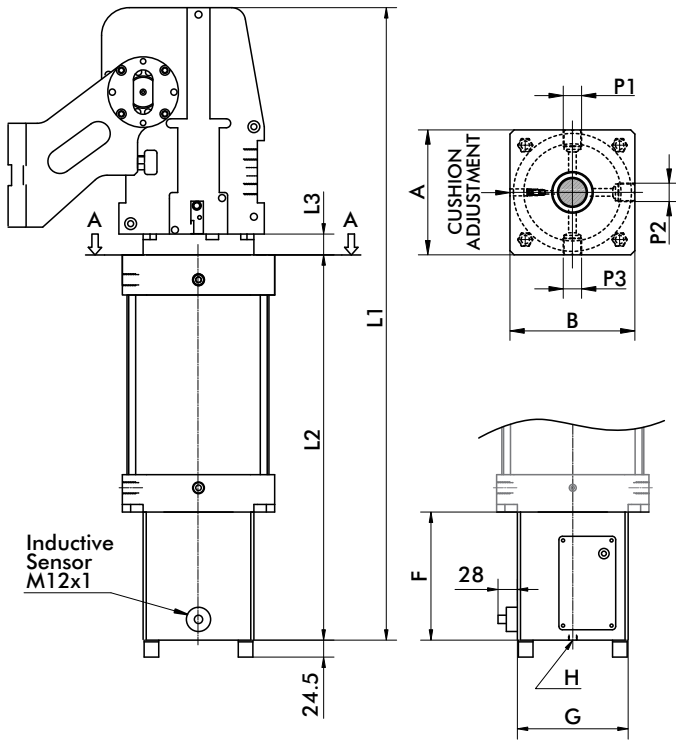

GR MODEL	L1	L2	L3	A-B	P3	P1 - P2	Weight
	mm						
GR100-45°	683.5	383.5					
GR100-90°	728.5	428.5	20	115	1/2" G	1/2" G or 1/2" NPT	36 kg [80 lb]
GR100-120°	758.0	458.0					
GR125-45°	818.0	466.0					
GR125-90°	867.0	515.0	25	160	1/2" G	1/2" G or 1/2" NPT	80 kg [176 lb]
GR125-120°	895.0	543.0					
GR160-45°	827.0	472.0					
GR160-90°	876.0	521.0	28	180	3/4" G	3/4" G or 3/4" NPT	95 kg [209 lb]
GR160-120°	804.0	547.0					
GR200-45°	835.0	478.0					
GR200-90°	884.0	527.0	30	220	3/4" G	3/4" G or 3/4" NPT	103 kg [226 lb]
GR200-120°	912.0	555.0					

NOTE: "P1-P2" DEPENDANT ON ORDERING CODE

GR MODEL	F	G	H
	mm		
GR100	136	115 SQ	1/4"
GR125	185	160 SQ	1/4"
GR160	185	160 SQ	1/4"
GR200	185	160 SQ	1/4"

RC Series Cylinder Dimensions

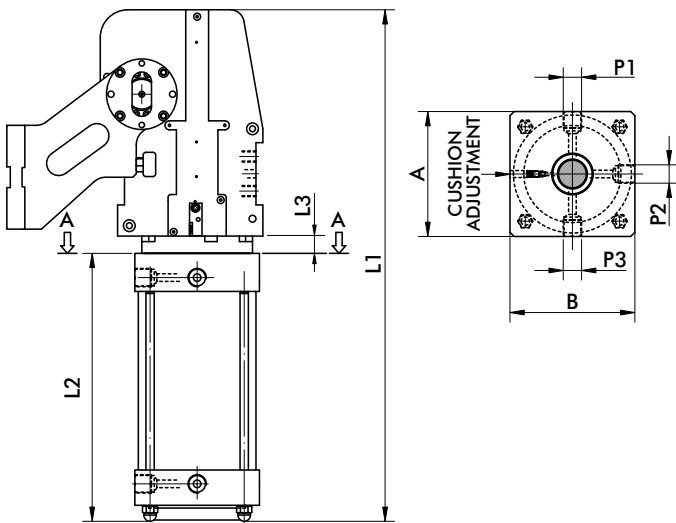

RC MODEL	L1	L2	L3	A-B	P3	P1 - P2	Weight
	mm						
RC100-45°	566.5	266.5					
RC100-90°	611.5	311.5	20	115	1/2" G	1/2" G or 1/2" NPT	29 kg [64 lb]
RC100-120°	641.0	341.0					
RC125-45°	656.0	304.0					
RC125-90°	705.0	353.0	25	160	1/2" G	1/2" G or 1/2" NPT	62 kg [137 lb]
RC125-120°	733.0	381.0					
RC160-45°	665.0	310.0					
RC160-90°	714.0	359.0	28	180	3/4" G	3/4" G or 3/4" NPT	77 kg [170 lb]
RC160-120°	742.0	387.0					
RC200-45°	670.0	313.0					
RC200-90°	719.0	362.0	30	220	3/4" G	3/4" G or 3/4" NPT	85 kg [187 lb]
RC200-120°	746.5	389.5					

NOTE: "P1-P2" DEPENDANT ON ORDERING CODE

GR & RC Series Optional Cylinder Orientation

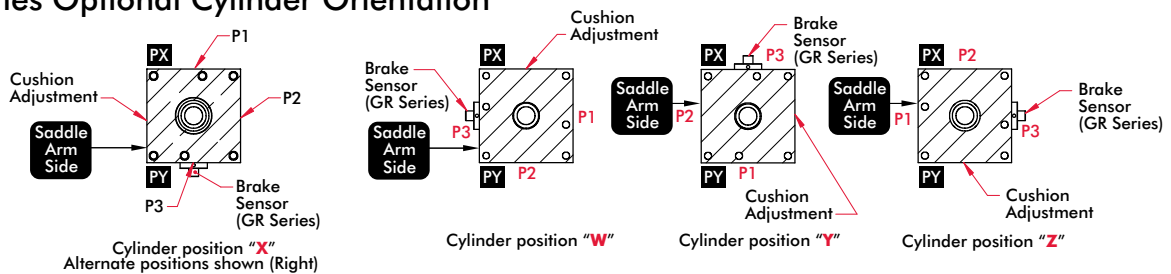

GR and RC Series Medium Duty Pivot Units

GR Series Hydraulic-Pneumatic Cylinder - Operating Principle

The GR Series uses a system which is divided into two cylinders; a pneumatic and a hydraulic cylinder. The pneumatic cylinder controls actuation of the pivot and the hydraulic cylinder controls motion and braking.

There is a 1:4 differential between the stroke of the pneumatic cylinder and the stroke of the hydraulic cylinder. The pitch of the threaded rod on the hydraulic side is less than the pitch on the ball screw on the pneumatic side. As the pneumatic cylinder is actuated, a non-rotating piston forces this ball screw to rotate and engages the movement of the hydraulic piston. The hydraulic piston cannot move until a poppet valve is engaged to allow oil to flow from one side of the piston to the other. If the poppet valve is not released, the brake is engaged.

The flow of oil from one side to the other is also controlled by an adjustable orifice. This orifice provides a dampening effect on the movement of the hydraulic piston and, in turn, the pneumatic actuator.

Please Note: The brake is not intended to be engaged on every cycle. It should be piped to remain open during normal operation and engaged only when air pressure to the cell has been interrupted.

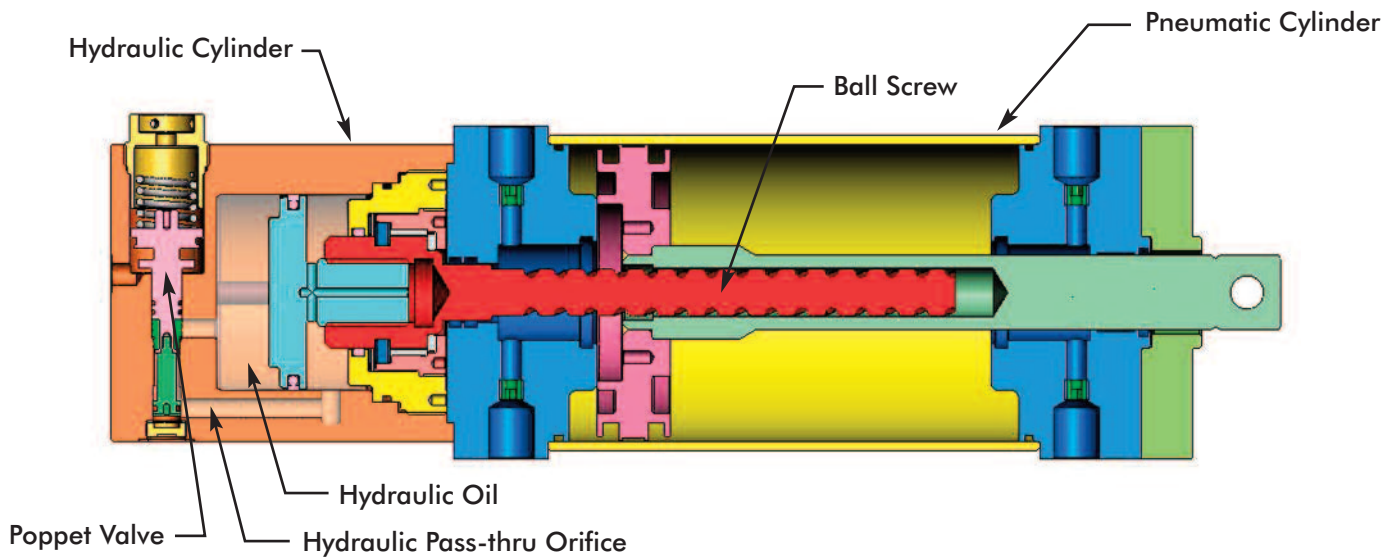

RC Series Hydraulic-Pneumatic Cylinder - Operating Principle

The RC Series pivot unit utilizes a hydraulic rod system completely contained within the pneumatic cylinder rod to control the mass moved by the pivot unit. The system works with hydraulic oil passing through an orifice in the fixed hydraulic piston rod between chambers within the hydro-pneumatic piston rod. The system has a fixed orifice and does not need adjustment. This system provides constant speed, eliminating sudden movement and abrupt impacts at the end of stroke.

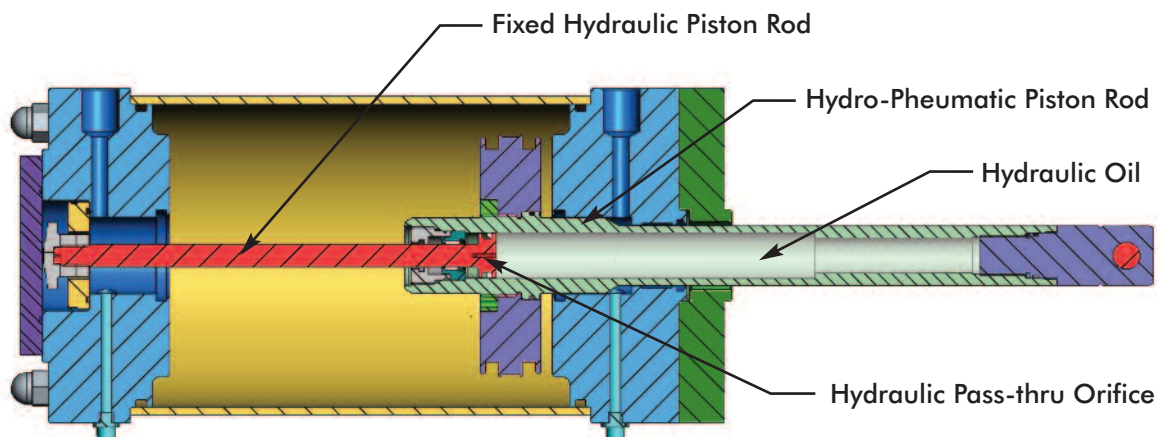

GR and RC Series Medium Duty Pivot Units

Maximum Torque for Weight

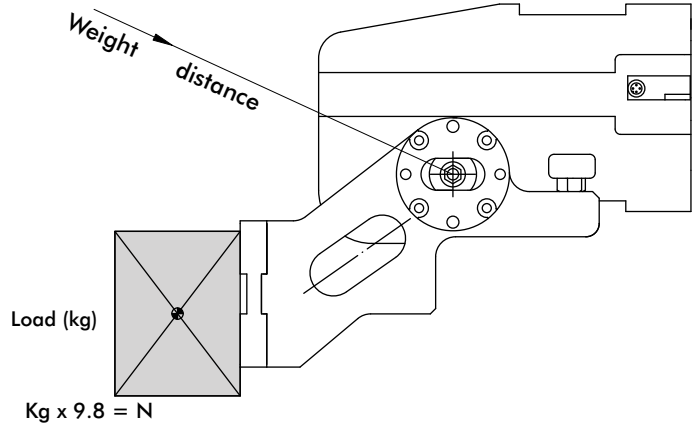
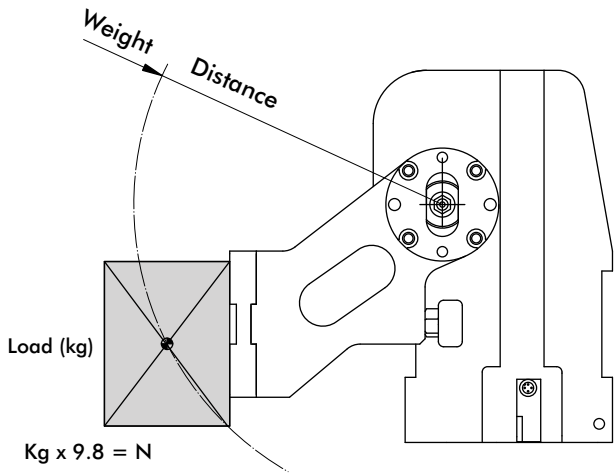

Model	Maximum Torque for Weight - ≤ 90° opening					
	58psi / 4 Bar		72psi / 5 Bar		87psi / 6 Bar	
	lbf*in	N*m	lbf*in	N*m	lbf*in	N*m
GR/RC100	1062	120	1328	150	1682	190
GR/RC125	1563	180	2124	240	2567	290
GR/RC160	2832	320	3629	410	4425	500
GR/RC200	4514	510	5841	660	7081	800

Model	Maximum Torque for Weight - > 90° opening					
	58psi / 4 Bar		72psi / 5 Bar		87psi / 6 Bar	
	lbf*in	N*m	lbf*in	N*m	lbf*in	N*m
GR/RC100	620	70	797	90	1062	120
GR/RC125	1239	140	1593	180	2036	230
GR/RC160	2124	240	2744	310	3540	400
GR/RC200	3629	410	4602	520	5488	620

Model	Maximum Torque with Side Load for Weight					
	58psi / 4 Bar		72psi / 5 Bar		87psi / 6 Bar	
	lbf*in	N*m	lbf*in	N*m	lbf*in	N*m
GR/RC100	708	80	708	80	708	80
GR/RC125	1770	200	1770	200	1770	200
GR/RC160	1770	200	1770	200	1770	200
GR/RC200	1770	200	1770	200	1770	200

Center of Gravity to Pivot (distance in Meters [Inches]) X Tooling Weight (N [lb]) = Torque for weight (N°m [lbf*in])
 Distance from Center of Gravity to pivot is measured parallel to the floor

Notes

The total torque for the application must be less than the Maximum Torque for a given pressure in the Maximum Torque for Weight charts above. For applications with a total torque greater than the Maximum Torque shown, please see RU Series Pivot Units.

Based on cycle time of 7-8 seconds. Flow controls must be used to provide this cycle time. Cushions must also be adjusted to provide deceleration to the load. Failure to control movement will severely damage unit and cause premature failure.

Use the following graphs to determine the maximum amount of tooling weight that is allowed. The tooling load should be placed as close to the center line of the unit as possible.

GR and RC Series Medium Duty Pivot Units

Maximum Added Tooling Weight less than 90°

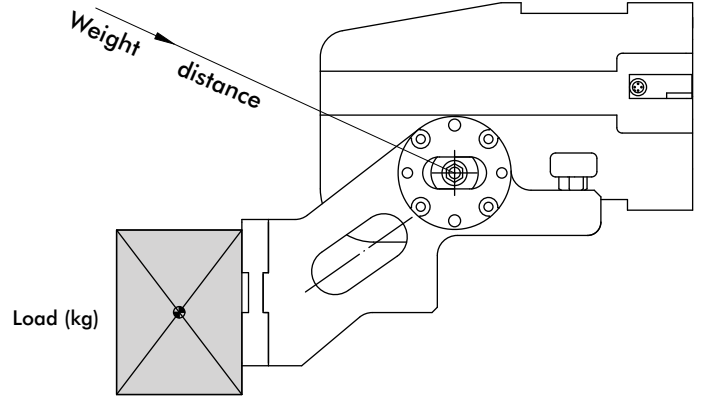
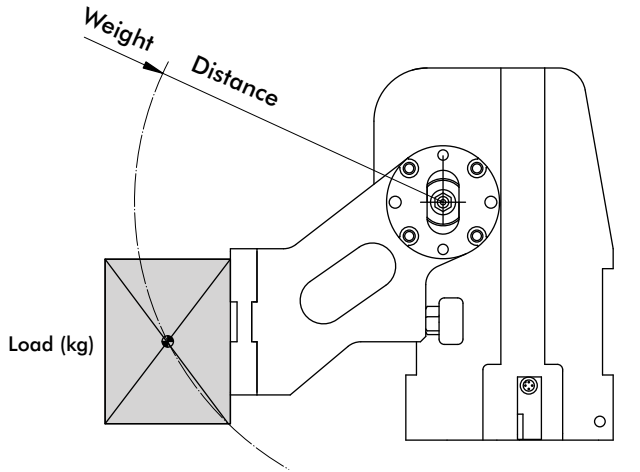

GR/RC 100

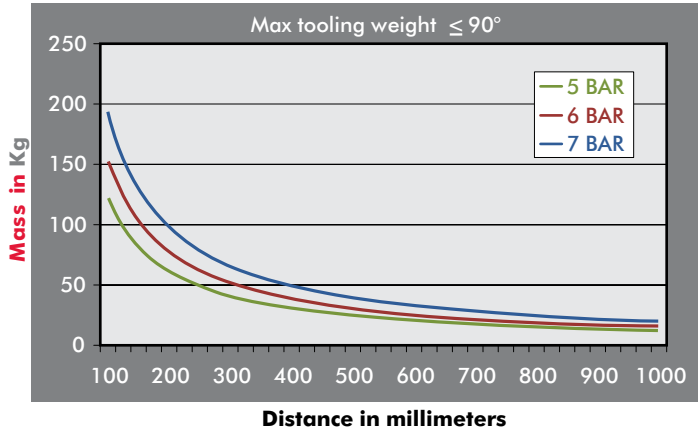

GR/RC 125

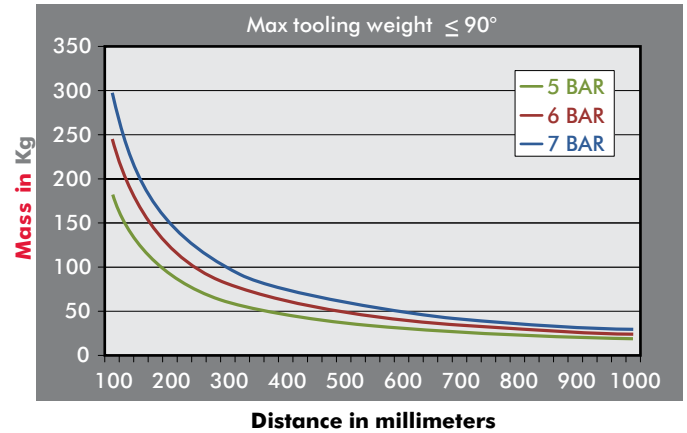

GR/RC 160

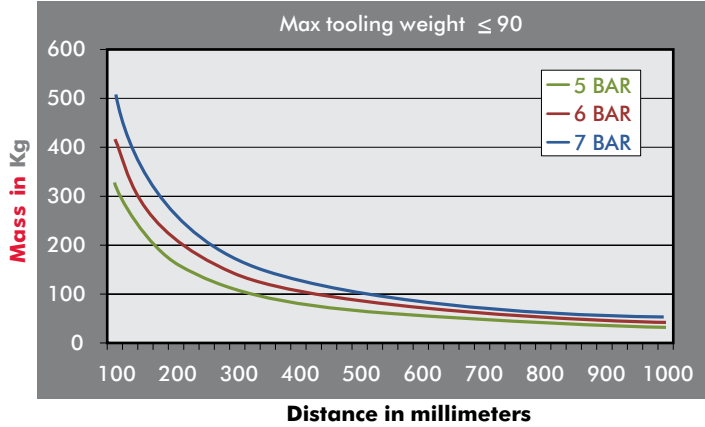

GR/RC 200

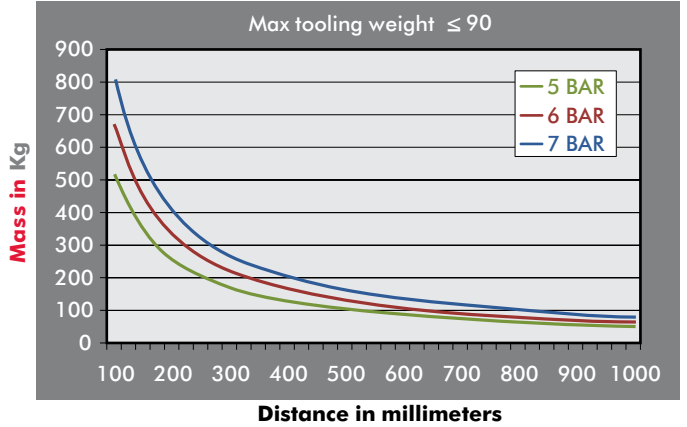

GR and RC Series Medium Duty Pivot Units

Maximum Added Tooling Weight Greater than 90°

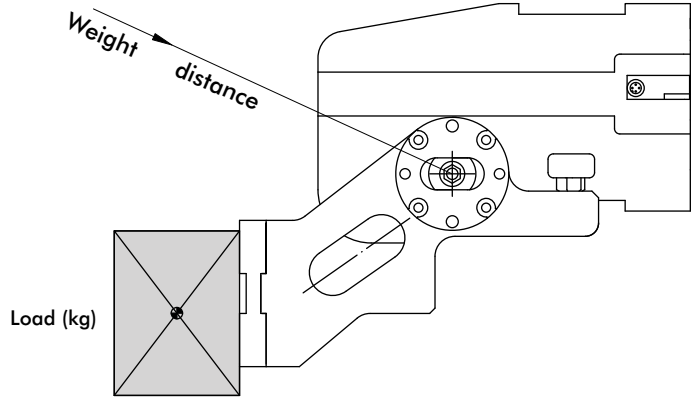
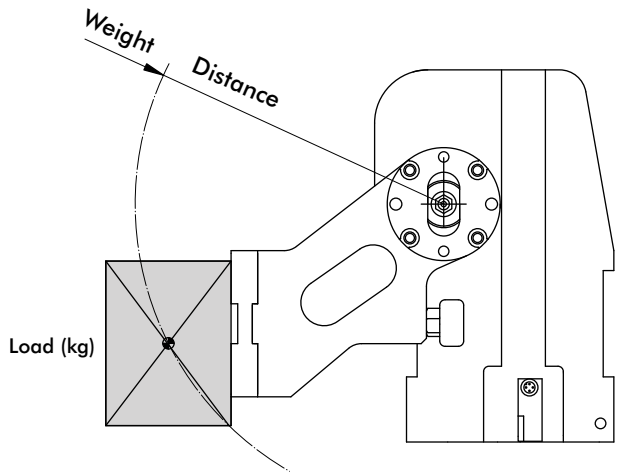

GR/RC 100

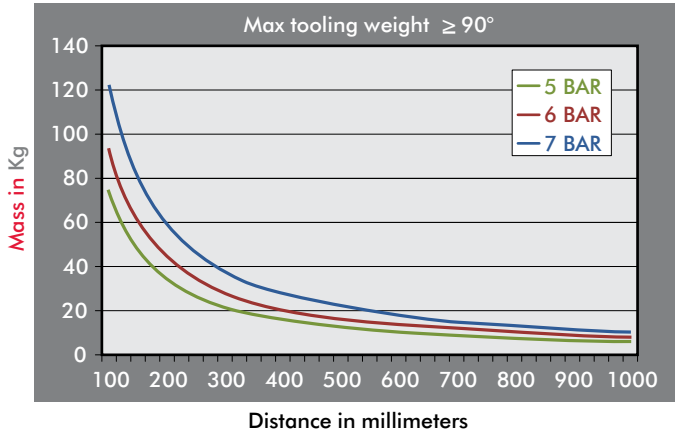

GR/RC 125

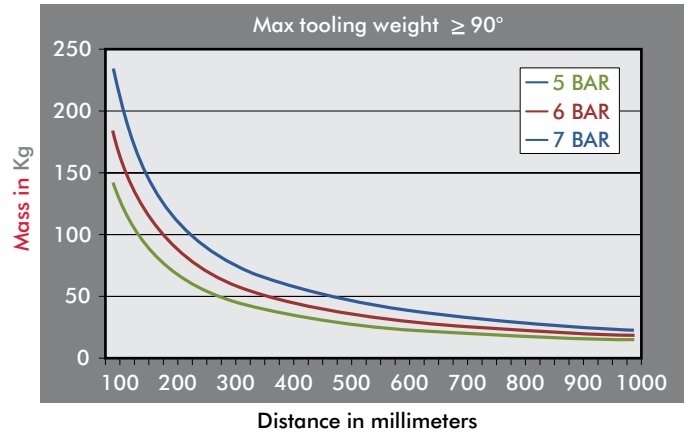

GR/RC 160

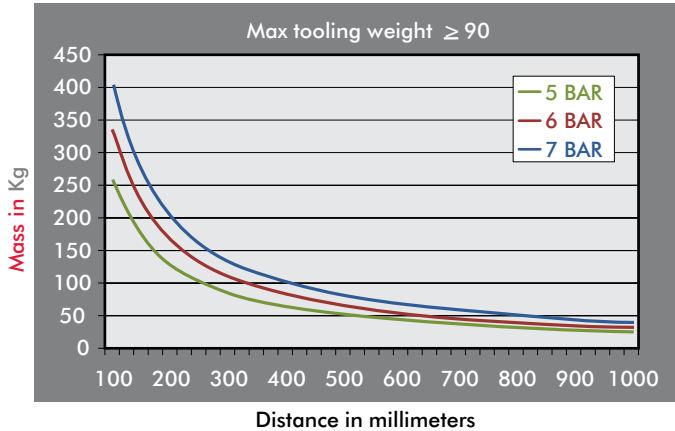

GR/RC 200

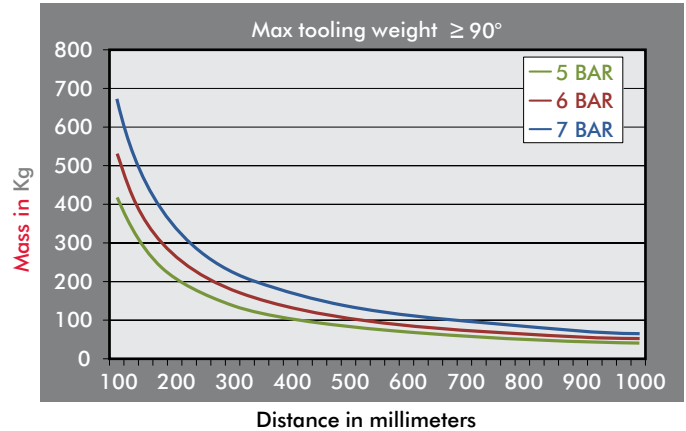

GR and RC Series Medium Duty Pivot Units

Force Charts for Opening Angles

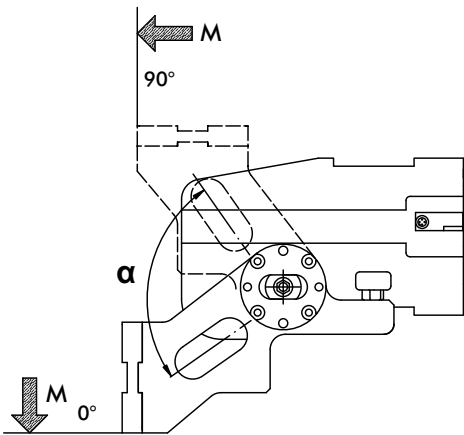

(Values calculated at 1 m from center of rotation)

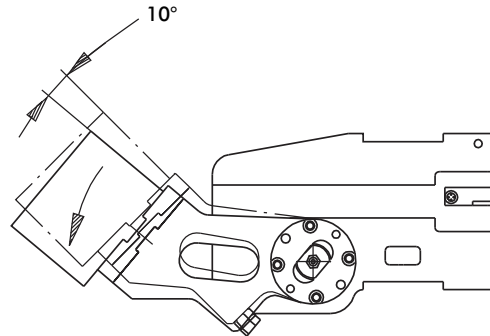

Play of swing arm while closed emergency stop value

Conditions:

- Emergency stop in operator
 - Cylinder depressurized
 - Max. load
- Max. play 10°

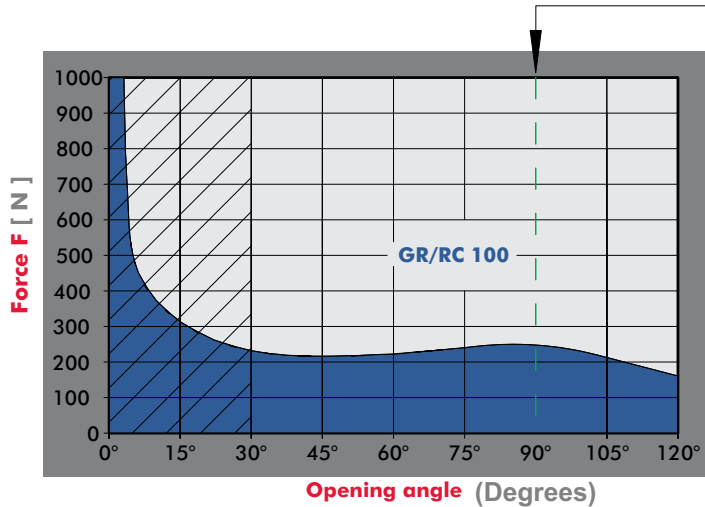

MODEL	TORQUE WITH ARM AT 90°
GR/RC 100	240 Nm
GR/RC 125	370 Nm
GR/RC 160	630 Nm
GR/RC 200	1000 Nm

NOTE: Values at 6 bar

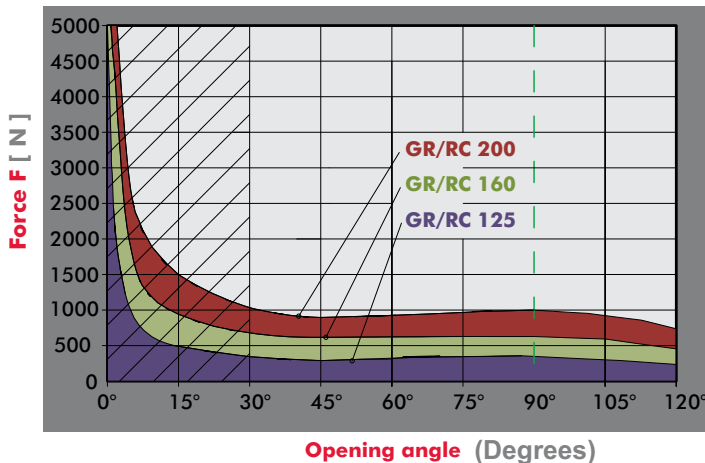

WARNING: Make sure that the tilting device runs a complete working cycle and reaches the angle position at 0°. (Any interference in the highlighted angle area may seriously damage both the tooling and the tilting device, as the result of the very high forces developed, as shown in the chart).

Do not use external stops with GR/RC Series Pivot Units!