

Series 202 Product Overview

Features:

- Two bar styles available
- Low profile T-Handle version available
- Available in stainless steel
- Accommodates M6 or 1/4" spindle accessories

Applications:

- Checking fixtures
- Assembly & test
- Light machining
- Woodworking

Also Available:

See page 8.1 for accessories

802-U Pneumatic Toggle Clamp
(See page 10.6)

202-U
Flanged Base
U-Bar

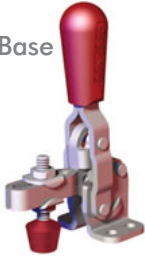

202-UL
Flanged Base
Long U-Bar

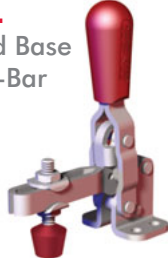

202-USS
Flanged Base
U-bar, Stainless
Steel



202
Flange Base
Solid Bar

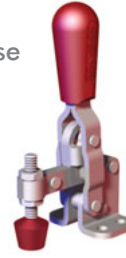

202-SS
Flanged Base
Solid Bar
Stainless Steel



202-UB
Straight Base
U-bar



202-B
Straight Base
Solid Bar



202-TU
Flanged Base
U-bar,
T-Handle

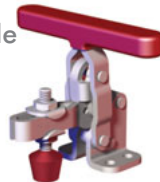

202-T
Flanged Base
Solid Bar
T-Handle

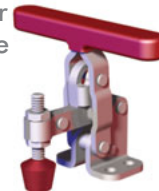

202-U-L
Flanged Base
Open U-Bar

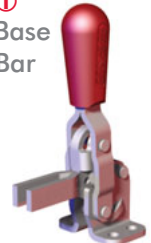

202-UB-L
Straight Base
Open U-Bar



Note:

Clamps shown with included accessories.



Series 202 Technical Information

Model	Max. Holding Capacity	Clamp Bar Opening (+10°)	Handle Opening (+10°)	Weight	Accessories (Supplied)	
					Spindle Assembly	Flanged Washers
202-U	890 N [200 lbf]	105°	65°	0,16kg [0.35lbs]	202208-M	215105
202-UL					202943	215905
202-USS	1110 N [250 lbf]			202208-M	---	
202	890 N [200 lbf]			202943	---	
202-SS	1110 N [250 lbf]			0,16kg [0.35lbs]	202208-M	215105
202-UB	0,15kg [0.33lbs]					
202-B	0,17kg [0.38lbs]					
202-TU	0,16kg [0.35lbs]					
202-T	---			---		
202-U-L ⓘ	---			---		
202-UB-L ⓘ	---	---				

ⓘ This item is available upon request

Series 202 Holding Capacities

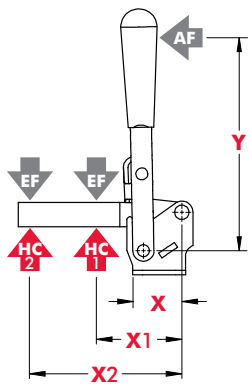

Model	X	X1	X2	Y	‡HC1	‡HC2	‡EF(X1):AF	‡EF(X2):AF
202-U			[2.25] 57	[3.42]	[200 lbf] 890N	[140 lbf] 625N		5:1
202-UL		[1.25] 32	[2.88] 73	87	890N	[150 lbf] 670N	10:1	4:1
202-USS			[2.25] 57	[3.00] 76	[250 lbf] 1110N	[170 lbf] 760N		5:1
202			[1.88] 48	[3.42] 87	---	[200 lbf] 890N	---	8:1
202-SS				[3.00] 76	---	[250 lbf] 1110N	---	
202-UB	[0.79] 20	[1.25] 32	[2.25] 57	[3.42]	[200 lbf] 890N	[140 lbf] 625N	10:1	5:1
202-B			[1.88] 48	87	---	[200 lbf] 890N	---	8:1
202-TU		[1.25] 32	[2.25] 57	[2.13]	[200 lbf] 890N	[140 lbf] 625N	11:1	7:1
202-T			[1.88] 48	54	---	[200 lbf] 890N	---	6:1
202-U-L ⓘ		[1.25] 32	[2.25] 57	[3.42]	[200 lbf] 890N	[140 lbf] 625N	10:1	5:1
202-UB-L ⓘ								

Dimensions shown "mm [inch]" ‡ HC = Holding Capacity, EF = Exerting Force, AF = Applied Force

ⓘ This item is available upon request

Series 202 Standard Clamp Dimensions
 202/-U/-UL/-USS/-SS/-UB/-B/-TU/-T

202-U[†]
 Flanged Base
 U-Bar

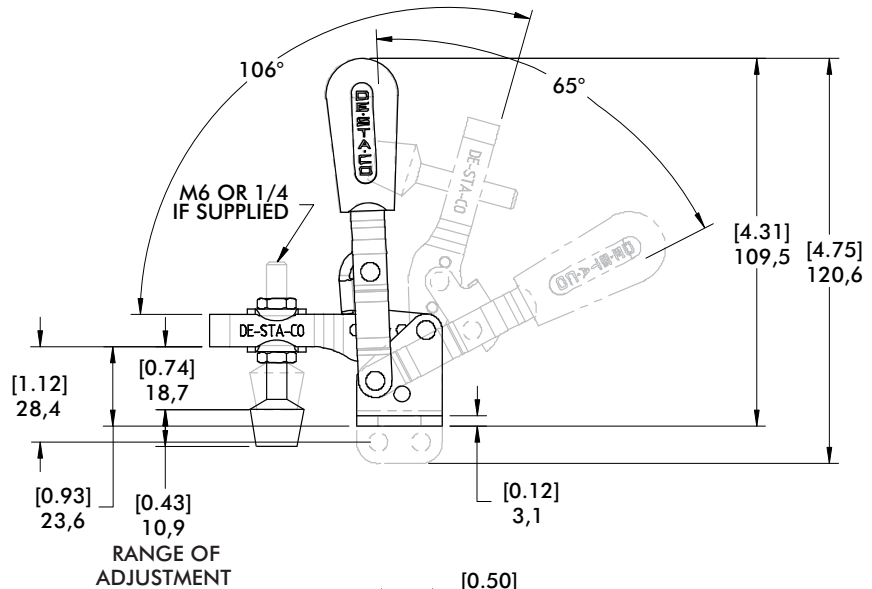
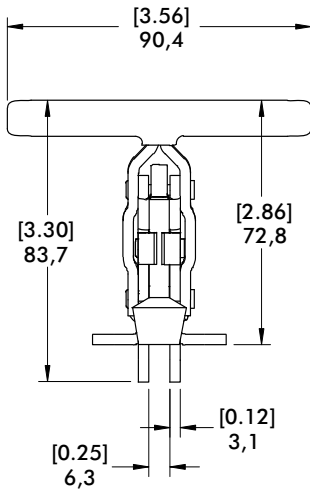
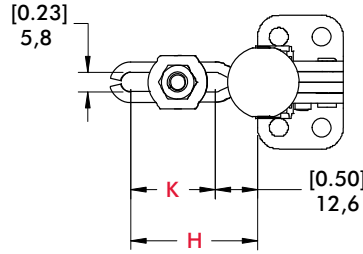

Series 202 Open Bar

Flanged Base
Model
 202-U-L ⓘ



See page (8.7) for Complete offering of Open bar accessories

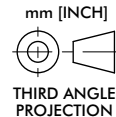
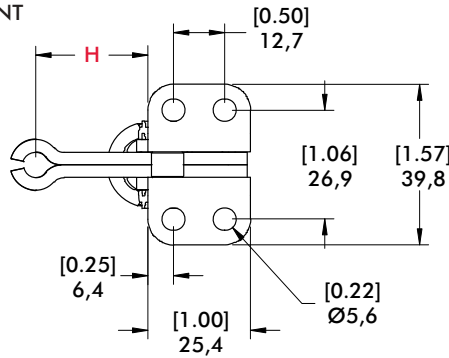
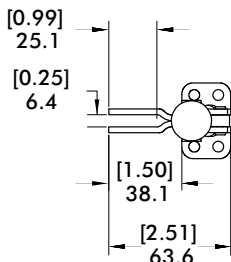

Straight Base
Model
 202-UB-L ⓘ



Bar Style	Clamp Models	H	K
	202-U/202-UB/ 202-USS/202-TU	[1.73] 44,1	[0.98] 25
	202-UL ⓘ	[2.29] 58,1	[1.51] 38,4
	202/202-B/ 202-T/202-SS	[1.31] 33,3	---
	202-U-L ⓘ/ 202-UB-L ⓘ	[1.50] 38,1	---

ⓘ This item is available upon request