

Series 5905, 5910, 5915 Product Overview

Features:

- High strength forged clamping arm for heavy-duty service
- Hardened steel pivot pins and bushings provide long life
- Black oxide finish
- Large clearance under the clamping bar

Applications:

- Welding fixtures
- Assembly fixtures



5905/5910/5915
Flanged Base



5905-B/5910-B
Solid Base



Series 5905, 5910, 5915 Technical Information

Model	Max. Holding Capacity	Clamp Bar Opening (+10°)	Handle Opening (+10°)	Weight
5905	[750lbf.] 3340N	135°	70°	[1.08lbs] 0,49kg
5905-B				[0.82lbs] 0,37kg
5905-R				[1.09lbs] 0,49kg
5905-BR				[0.83lbs] 0,37kg
5910	[1600lbf.] 7120N	132°	71°	[2.84lbs] 1,29kg
5910-B				[2.24lbs] 1,02kg
5910-R				[2.87lbs] 1,30kg
5910-BR				[2.27lbs] 1,03kg
5915	[2750lbf.] 12230N	147°	74°	[6.44lbs] 2,92kg



Removable handle stop can be repositioned to limit opening angle to 90°

Series 5905, 5910, 5915 Standard Clamp Dimensions

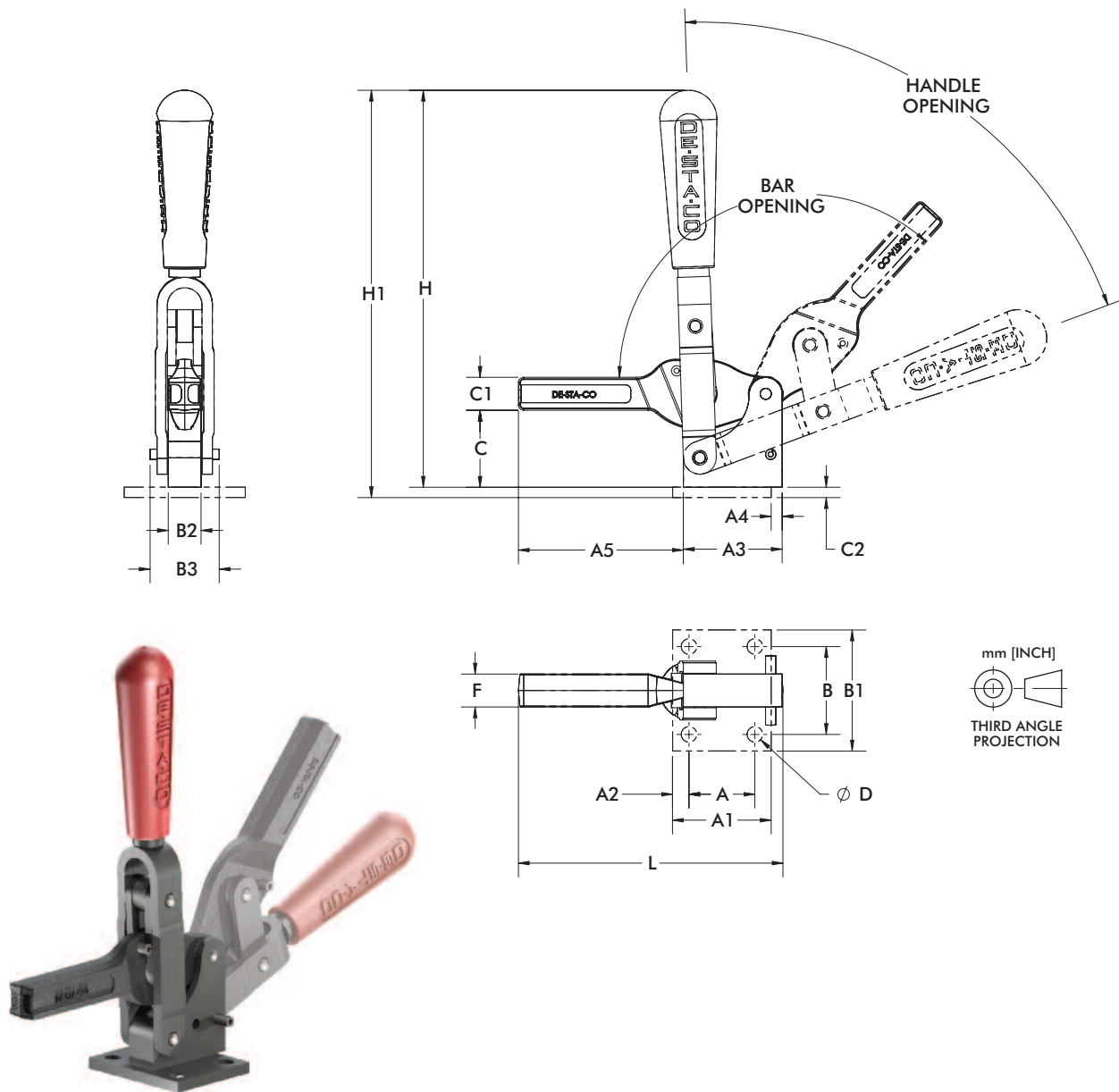

mm [INCH]

 THIRD ANGLE PROJECTION

Model	A	A1	A2	A3	A4	A5	B	B1	B2	B3	C	C1	C2	D	F	H	H1	L
5905	[1.00] 25,4	[1.50] 38,1	[0.25] 6,4	[1.51] 38,4	[0.25] 6,4	[2.49] 63,2	[1.50] 38,1	[2.13] 54,1	[0.59] 15,0	[1.02] 25,9	[1.27] 32,3	[0.51] 12,9	[0.24] 6,1	[0.29] 7,3	[0.56] 14,2	[6.51] 165,4	[6.75] 171,4	[4.02] 102.10
5910	[1.50] 38,1	[2.24] 56,9	[0.37] 9,4	[2.25] 57,2	[0.25] 6,4	[3.76] 95,5	[2.00] 50,8	[2.76] 70,1	[0.75] 19,1	[1.57] 39,9	[1.75] 44,5	[0.75] 19,1	[0.24] 6,1	[0.41] 10,5	[0.56] 14,2	[9.04] 229,5	[9.27] 235,5	[6.02] 152.88
5915	[2.00] 50,8	[2.95] 74,9	[0.48] 12,2	[2.99] 75,9	[0.38] 9,7	[5.00] 127,0	[2.75] 69,9	[3.88] 98,6	[0.98] 24,9	[1.97] 50,0	[2.37] 60,2	[1.00] 25,4	[0.35] 8,9	[0.55] 14,0	[1.00] 25,4	[10.89] 276,7	[11.25] 285,7	[7.50] 190.50

Model	A3	A5	B2	B3	F	H
5905-B	[1.51] 38,4	[2.49] 63,2	[0.59] 15,0	[1.02] 25,9	[0.56] 12,2	[6.24] 158,5
5910-B	[2.25] 57,2	[3.76] 95,5	[0.75] 19,1	[1.57] 39,9	[0.75] 19,1	[8.72] 221,5